



Roll No:

--	--	--	--	--	--	--	--	--	--	--	--	--	--	--

BTECH
(SEM IV) THEORY EXAMINATION 2024-25
INTRODUCTION TO SOLID MECHANICS

TIME: 3 HRS

M.MARKS: 70

Note: Attempt all Sections. In case of any missing data, choose suitably.

SECTION A

1. Attempt all questions in brief.

02 x 7 = 14

Q no.	Question	CO	Level
a.	Write the relationship between Young's Modulus, Bulk Modulus, and Modulus of Rigidity.	1	K2
b.	What is the significance of the point of contra flexure in a bending moment diagram? Under what conditions does it occur?	2	K2
c.	Differentiate between an overhanging beam and a propped cantilever beam.	1	K2
d.	Explain the procedure to determine the section modulus for a circular cross-section.	2	K4
e.	Differentiate between thin cylinders and thick cylinders in terms of assumptions and stress distribution.	2	K3
f.	Define buckling and explain the meaning and importance of the slenderness ratio.	3	K4
g.	Define torsion. Provide two practical examples where a structural member experiences pure torsion.	2	K2

SECTION B

2. Attempt any three of the following:

07 x 3 = 21

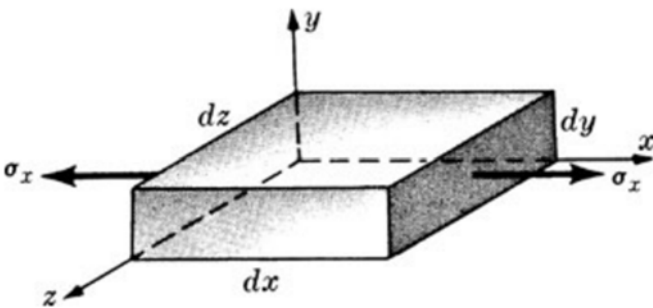
Q no.	Question	CO	Level
a.	<p>Consider an elemental block subject to uniaxial tension as shown in figure below. Derive approximate expressions for the change of volume per unit volume due to this loading.</p> 	1	K2
b.	The beam AC is simply supported at A and C and subject to the uniformly distributed load of 300 N/m plus the couple of magnitude 2700 N·m as shown in Figure. Write equations for shearing force and bending moment and make sketches of these equations.	2	K4



Roll No:

--	--	--	--	--	--	--	--	--	--	--	--	--	--	--	--	--	--	--	--

BTECH
(SEM IV) THEORY EXAMINATION 2024-25
INTRODUCTION TO SOLID MECHANICS

TIME: 3 HRS

M.MARKS: 70

c.	Derive the expression for normal stress in a beam subjected to pure bending (flexure). What are the fundamental assumptions made in deriving this bending equation? Illustrate the distribution of normal stresses across the beam cross-section using a suitable diagram.	2	K3
d.	State the failure criterion and provide the mathematical expression for each of the following failure theories: Maximum Principal Strain Theory Maximum Shearing Stress Theory Strain Energy Theory Distortion Energy Theory	3	K4
e.	What largest internal pressure can be applied to a cylindrical tank 1.8 m in diameter and 14 mm wall thickness if the ultimate tensile strength of steel used is 467 MPa and a factor of safety of 7 is desired?	4	K5

SECTION C

3. Attempt any one part of the following:

07 x 1 = 07

Q no.	Question	CO	Level
a.	An aluminum cube is subjected to a hydrostatic pressure of 2.0 MPa. Due to this pressure, the volume decreases resulting in a dilatation of -1.2×10^{-5} . If the Young's modulus of the material is 210 GPa, determine the Poisson's ratio of the material and also compute the bulk modulus.	3	K4
b.	<p>The composite bar shown in Figure below is rigidly attached to the two supports.</p> <p>The left portion of the bar is copper, of uniform cross-sectional area 80 cm^2 and length 30 cm. The right portion is aluminum, of uniform cross-</p>	4	K5



Roll No:

--	--	--	--	--	--	--	--	--	--	--	--	--	--	--	--

BTECH
(SEM IV) THEORY EXAMINATION 2024-25
INTRODUCTION TO SOLID MECHANICS

TIME: 3 HRS

M.MARKS: 70

<p>sectional area 20 cm^2 and length 20 cm. At a temperature of 26°C the entire assembly is stress free. The temperature of the structure drops and during this process the right support yields 0.025 mm in the direction of the contracting metal. Determine the minimum temperature to which the assembly may be subjected in order that the stress in the aluminum does not exceed 160 MPa. For copper $E = 100 \text{ GPa}$, $\alpha = 17 \times 10^{-6}/^\circ\text{C}$, and for aluminum $E = 80 \text{ GPa}$, $\alpha = 23 \times 10^{-6}/^\circ\text{C}$.</p>		
---	--	--

4. Attempt any one part of the following:

07 x 1 = 07

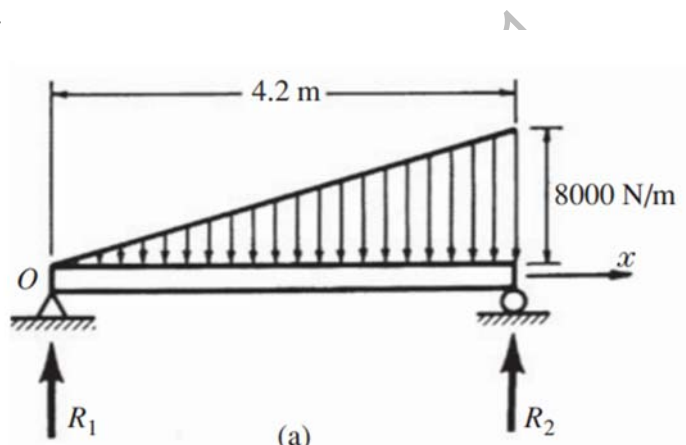
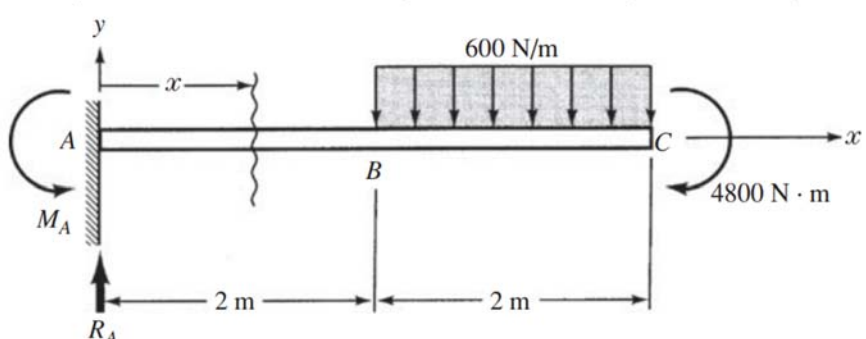
Q no.	Question	CO	Level
a.	<p>The simply supported beam shown in Figure carries a vertical load that increases uniformly from zero at the left end to a maximum value of 8000 N/m at the right end. Draw the shearing force and bending moment diagrams.</p>  <p style="text-align: center;">(a)</p>	3	K4
b.	<p>The cantilever beam AC in Figure is loaded by the uniform load of 600 N/m over the length BC together with the couple of magnitude $4800 \text{ N}\cdot\text{m}$ at the tip C. Determine the shearing force and bending moment diagrams.</p> 	4	K5



Roll No:

--	--	--	--	--	--	--	--	--	--	--	--	--	--	--	--	--	--	--	--

BTECH
(SEM IV) THEORY EXAMINATION 2024-25
INTRODUCTION TO SOLID MECHANICS

TIME: 3 HRS

M.MARKS: 70

5. Attempt any *one* part of the following:

07 x 1 = 07

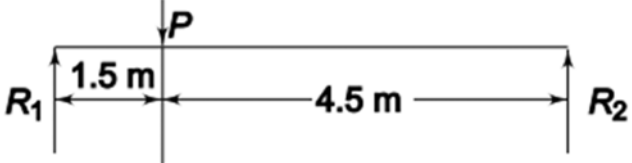
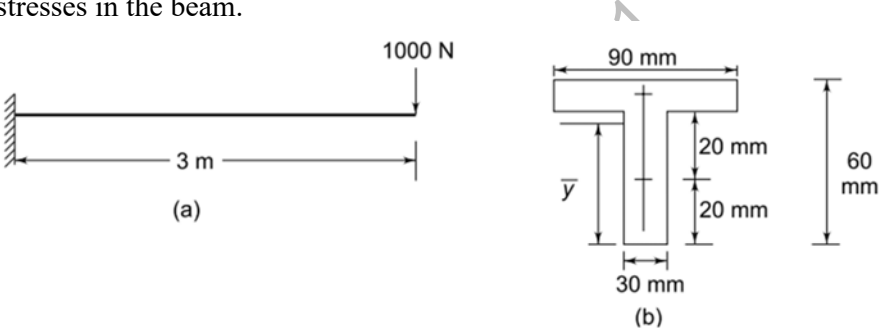
Q no.	Question	CO	Level
a.	<p>A simply supported timber beam 6 m long (refer Figure) carries a single concentrated load P. The beam has 100 mm by 300 mm rectangular cross-section. Determine the maximum value of P if the fiber stress is not to exceed 8.25 MN/m^2 and 100 mm side is horizontal.</p> 	3	K4
b.	<p>A cantilever 3 m long has a T-section as shown in Figure. It carries a load of 1000 N at the free end. Calculate the maximum tensile and compressive stresses in the beam.</p> 	4	K5

6. Attempt any *one* part of the following:

07 x 1 = 07

Q no.	Question	CO	Level
a.	A short column of rectangular cross-section 200 mm by 150 mm carries a load of 400 kN at a point 50 mm from longer side and 87.5 mm from the shorter side. What are the maximum compressive and tensile stresses in the section?	3	K4
b.	At a point in a stressed body the normal stresses are 83 N/mm^2 (tensile) on a vertical plane and 27.5 N/mm^2 (compressive) on a horizontal plane. A shearing stress of 41.4 N/mm^2 acts at this point. Determine and show on a sketch the principal stress and the maximum shearing stress at this point.	2	K3

7. Attempt any *one* part of the following:

07 x 1 = 07

Q no.	Question	CO	Level
a.	Derive the expressions for the longitudinal strain, hoop strain, and change in volume of a thin-walled cylindrical shell subjected to a uniform internal pressure. Assume the cylinder is closed at both ends and thin enough to apply thin cylinder theory.	5	K2
b.	Derive the torsion equation for circular shafts. Also, list the assumptions made in the derivation.	4	K5